

The Importance of the Counterion. The Relative Energies of Homocubyl Cations and Ion Pairs¹

William L. Jorgensen

Contribution from the Department of Chemistry, Purdue University, West Lafayette, Indiana 47907. Received November 23, 1976

Abstract: The structures and relative energies of a series of (CH)₉ cations in the gas phase and in model ion pairs have been calculated using MINDO/3 and perturbation theory methods. In the gas phase, the bishomocubyl cation, **2**, the novel pyramidal ion, **4**, and the homocubyl cation, **1**, are found to be similar in energy with **4** the most stable and **1** the least stable. The energetic proximity suggests that complete carbon scrambling should be facile for isolated **1**. In order to better approximate the situation in solution, complexes of the carbonium ions with HCl were studied as model ion pairs. A simple perturbation theory expression is found to be useful in analyzing the origin of the differences in the interaction energies between the cations and counter molecule in the complexes. Due to the substantially different charge distributions and energetic similarity of the isolated cations, the relative energies of the model ion pairs are in a distinctly different order: **1** < **4** < **2**. Qualitatively, the results imply that relatively localized carbonium ions, such as **1**, are better stabilized by a solvated leaving group than more delocalized species, e.g., **2** and **4**. Furthermore, it is apparent that caution must be exercised in using relative energies of carbonium ions in the gas phase as a gauge for the relative energies of intermediates in solution.

The homocubyl cation (**1**) is a topologically unusual species because it can, in principle, undergo complete carbon scrambling by a series of 1,2-carbon shifts. The solvolytic work

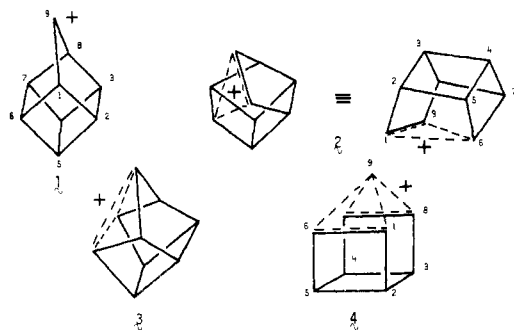

of Schleyer,³ Pettit,⁴ and Dauben⁵ has shown, however, that the full degeneracy of **1** is difficult to achieve. Deuterium labeling studies suggested that the partial scrambling is due to stereospecific rearrangements involving only the CC bonds trans to the leaving group (eq 1). Thus, under acetolysis con-

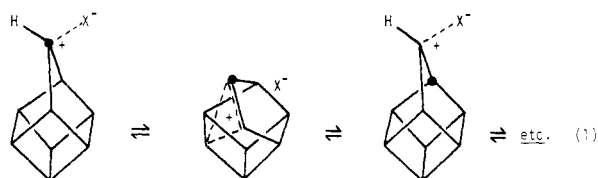

ditions a free ion is apparently not formed which is reasonable for a secondary species.⁶

The exact nature of the carbonium ion part of the ion pairs has not been established. The most obvious options are **1** in either C_{2v} (bridge vertical) or C_s (bridge bent to one side) symmetry; the bishomocyclopropenium ion, **2** (the midpoint for the 1,2-shift); the trishomocyclopropenium ion, **3** (analogous to Coates' cation,⁷ **5**); and the pyramidal isomer, **4**. Two

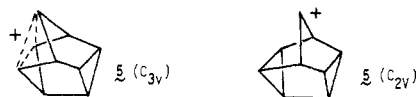

facts have been interpreted as possible support for a bridged intermediate: (1) the stereospecificity of the rearrangements,^{3,4} and (2) the rate enhancement of 400 based on the Foote-Schleyer model⁸ observed for acetolysis of 9-homocubyl tosylate.³ Bridged species analogous to **2** have also been impli-

cated in the solvolyses of bishomocubyl derivatives,^{8,9} however, attempts at their preparation in superacid have been unsuccessful.¹⁰

The present study was undertaken to help clarify the relative energies of the isolated ions, **1–4**, and corresponding ion pairs. The approach that is used is a theoretical one featuring MINDO/3¹⁰ and perturbation theory calculations. The same procedure has been applied to similar problems in the past.^{2,7b,12} A novel feature is the use of carbonium ion-HCl complexes to model the ion pairs. On the basis of our previous studies,² it is anticipated that the presence of solvent or a solvated leaving group should stabilize the more localized ion, **1**, to a greater extent than the more delocalized isomers, **2–4**. Therefore, an intriguing point is whether the energetic ordering of the isolated ions is the same as for the ion pairs. The results reinforce the notion that the relative energies of carbonium ions in the gas phase do not necessarily dictate the nature of intermediates in solution.

Results for the Isolated Ions

Initially, MINDO/3 calculations were performed with complete geometry optimization for **1** in C_{2v} symmetry. The resultant structure was then allowed to relax in C_s symmetry which yielded a minimum corresponding to **1** with the bridge bent 27° to one side. Bending the bridge further produced a second minimum, **4**, which when fully optimized has C_{2v} symmetry. No minimum corresponding to **3** could be found. Finally, the minimum for **2** was determined in C_s symmetry. As shown in Table I, the relative energies of the four species are remarkably close with **4** the most stable and **4** < **2** < **1** (C_s) < **1** (C_{2v}). However, in view of the similarity of the energies and the reliability of MINDO/3 calculations, the results indicate little more than that the four ions are roughly isoenergetic. The calculated structures for the ions are given in Figures 1–4 and the charge distributions are in Table II. Since **1** (C_s), **2**, and **4** were optimized with a symmetry constraint and the activation energies for their interconversions were not determined, it cannot be said with certainty whether or not they are absolute minima. The findings for the complexes of these ions with HCl discussed below strongly suggest that, at least, **2** and **4** are true minima.

The relative energies of Coates' cation, **5** (C_{3v}), and the transition state for its bridge flipping, **5** (C_{2v}), are also included in Table I.^{7b} The significantly lower energy of **5** is consistent with the well-known, silver ion catalyzed isomerizations of homocubyl derivatives to derivatives of Coates' system

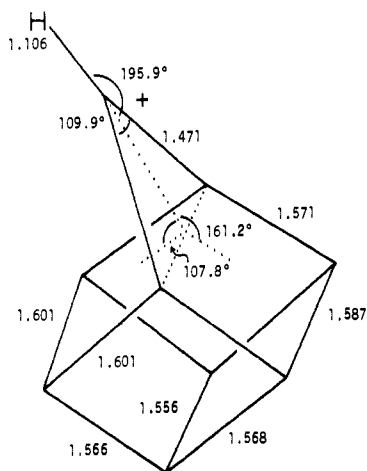

Figure 1. Important structural parameters calculated for $1(C_s)$. Complete coordinates are given in the supplementary material.

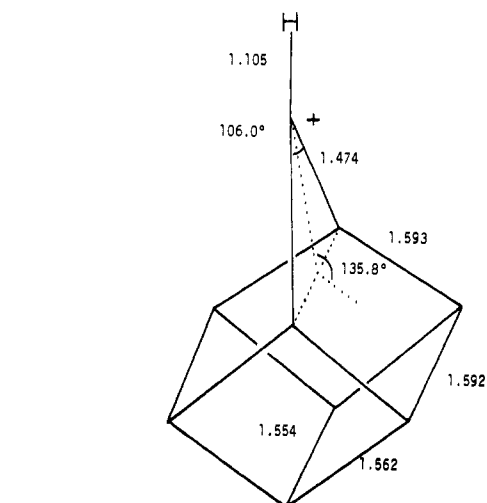

Figure 2. Important structural parameters calculated for $1(C_{2v})$.

Table I. Relative Energies of C_9H_9 Cations^a

Cation	Symmetry	Rel energy
1	C_s	4.8
1	C_{2v}	6.4
2	C_s	3.7
4	C_{2v}	0
5 ^b	C_{3v}	-35.8
5 ^b	C_{2v}	-13.7

^a MINDO/3 results in kcal/mol. ^b From ref 7b.

Table II. Charge Distributions for C_9H_9 Cations^a

Atom	$1(C_s)^b$	$1(C_{2v})$	2	4
C1	-0.036	-0.070	0.132	0.100
C2	0.029	0.054	0.000	0.017
C3			0.028	
C4	0.036	0.023	0.025	
C5			0.053	
C6	0.043		0.038	
C9	0.342	0.401		-0.030
Total on C	0.488	0.524	0.462	0.437

^a MINDO/3 results in electrons. ^b Bridge bent toward C6C7.

(norsnoutanes) and analogous isomerizations of bishomocubanes.¹³ As discussed previously,^{7b} the calculated bridge flipping barrier for **5** (22.1 kcal/mol) seems reliable due to the agreement between the calculated and experimental^{7a} values for the same process in 9-methyl-**5** and the similarity of these barriers to those for the 7-norbornadienyl cation and its 7-methyl analogue.¹⁴ It should be noted that the experimental determinations are made by NMR in superacid, while the calculated values apply to the gas phase. In view of our recent work,² which claims that the relative energies of isomeric carbocations exhibiting substantially different charge delocalization may vary from solution to the gas phase, the agreement for the bridge flipping barriers is consistent with weak solvation in superacid. This condition was anticipated² and is attributable to an absence in superacid of species that are good electron donors.

In contrast to Coates' cation, it is notable that **3** is not a minimum. This appears to be another manifestation of the difference between cyclopropyl (**5**) and cyclobutyl (**3**) edge participation.¹⁵ On the other hand, the pyramidal ion, **4**, does not have an analogue in Coates' system. Some observations can

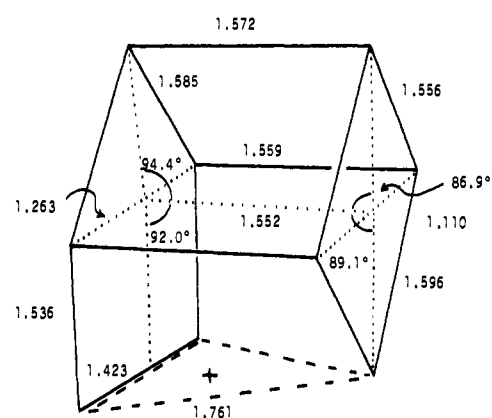
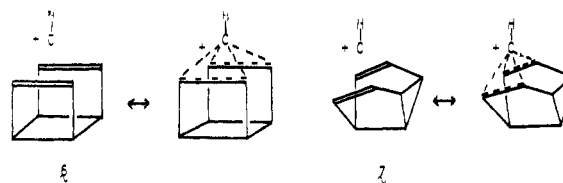
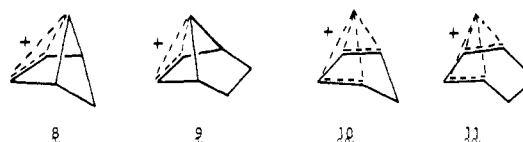

Figure 3. Important structural parameters calculated for **2**.

be made concerning this dichotomy. **4** may be described as a complex between CH^+ and the symmetric diene, *syn*-tricyclo[4.2.0.0^{2,5}]octadiene (**6**). The corresponding complex for



5 would be between CH^+ and the unsymmetric diene, semibullvalene (**7**). To date, pyramidal structures have not been established for any carbonium ions in which an unsymmetrical diene is formally involved, e.g., **8** and **9** are found, not **10** and



11.¹⁶ This must be due, to some extent, to the obvious fact that the interactions between CH^+ and one set of termini in an unsymmetric diene must be stronger than for the alternative termini. However, it seems that it should be possible by proper choice of dienes to obtain all gradations between structures such as **3** and **4** or **8** and **10**. This matter deserves further attention.¹⁷

The results in Table I imply that complete carbon scrambling would be facile for the homocubyl cation in the gas phase. This could be achieved by interconversions of ions like **4** via

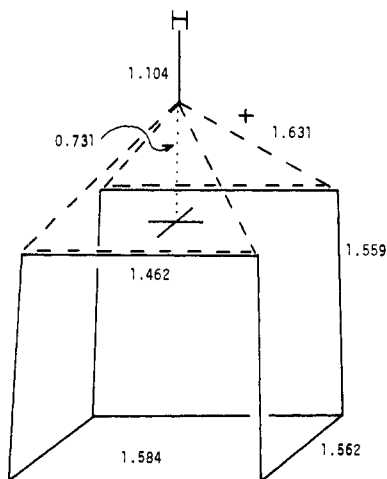

Figure 4. Important structural parameters calculated for **4**.

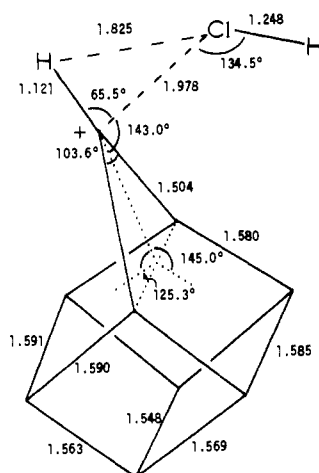
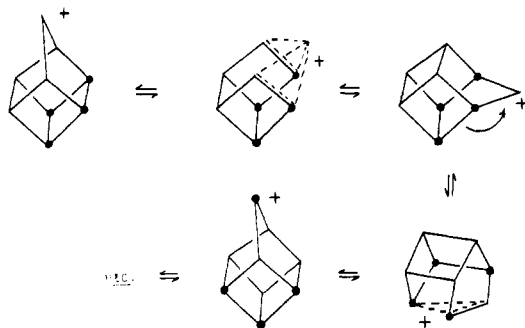
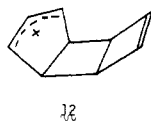

Figure 5. Important structural parameters calculated for **1-CiH** in C_s symmetry.

Scheme I



1 (C_{2v}) in conjunction with 1,2-shifts of **2** via **1** (C_s) as shown in Scheme I or by interconversions of **1** (C_s), **1** (C_{2v}), and **2**. It is assumed that **1** (C_{2v}) and **1** (C_s) approximate the transition states for these processes. Naturally, rearrangement to more stable isomers such as **5** or **12** could also be expected in the gas



phase. Similar behavior may complicate experiments on homocubyl cations in superacid.

These predictions clearly do not agree with the observed difficulty in achieving carbon degeneracy that was found under

Table III. Relative Energies of Carbonium Ion-HCl Complexes^a

Cation	Symmetry	Rel energy
1	C_s	0
1	" C_{2v} "	(5.5) ^b
2	C_1	6.6 ^c
4	C_1	3.2 ^c

^a MINDO/3 results in kcal/mol. ^b HCl fragment optimized; geometry of **1** (C_{2v}) taken from the calculation on the isolated ion. ^c Hydrogen bonded form.

Table IV. LUMO Charges, LUMO Energies, and Specific Solvation Factors for Carbonium Ions and Stabilization Energies for $R^+ \cdots ClH$

R^+	Q_L (C^{+a})	$-\epsilon_L$, eV ^a	f_s^a	$\Delta E_s^{a,b}$	$\Delta E_s^{est\ b,c}$
1 (C_s)	0.720	5.46	0.108	14.8	11.6
1 (" C_{2v} ")	0.734	6.18	0.124	(10.8) ^d	13.3
2	0.356	4.35	0.046	7.1	4.9
4	0.210	4.60	0.028	6.9	3.0
5 (C_{3v})	0.409	3.51	0.048		5.1

^a MINDO/3 results. $Q_L(C^+)$ is the electron density for the carbonium carbon in the LUMO (eq 4). ϵ_L is the orbital energy of the LUMO. ΔE_s 's are in kcal/mol. f_s is defined in eq 2. ^b Stabilization energies relative to separated cation and HCl. ^c Calculated using eq 3 with $a = 107.2$. ^d See footnote *b* of Table III.

acetolysis conditions.^{3,4} However, since free ions are apparently not formed during the solvolyses, there is no reason to expect that the relative energies of ion pairs involving **1**, **2**, and **4** are the same as for the isolated ions.

Results for the Ion Pairs

To probe this issue, MINDO/3 calculations have been performed on model ion pairs consisting of the carbonium ions and an HCl molecule. Although the model is crude, it has been useful in studying solvent effects on carbocations² and should reveal general trends. Formally, the carbonium ion-HCl complexes can be considered to represent a tight ion pair, or more properly a tight ion dipole,¹⁹ between the cation and the solvated leaving group (Cl^- solvated by H^+). Naturally, the choice of counter molecule influences the results. HCl has been selected since it interacts relatively weakly with carbonium ions and minimizes steric concerns.² The calculated interaction energy of HCl and simple secondary and tertiary carbocations was found to be generally 11–16 kcal/mol.²

In view of the similarity of the energies of the isolated ions (Table I) and their very different charge delocalization (Table II), it is not surprising that the relative energies of the ion pairs display a dramatically different order. As shown in Table III, the complex with **1** is the most stable followed by **4** and **2**. The calculated structure of **1-CiH** is given in Figure 5. In contrast to Figure 5, no minima could be found for the bridged species, **2** and **4**, with the chlorine associated with a carbon. The only minima that were found were for hydrogen bonded forms with nearly linear H-Cl- -H-C fragments. There is little preference for different hydrogens: the hydrogen bond energies are all roughly 7 kcal/mol while the stabilization energy for **1-CiH** is 14.8 kcal/mol. These data are summarized in the fifth column of Table IV. The fact that minima were found for the hydrogen bonded forms with no geometric constraints indicates that isolated **2** and **4** are true minima as discussed above.

At this point, it must be asked: Could additional solvation return the energetic order of the ion pairs to that for the isolated ions? A similar question has been addressed previously in the context of the solvation of bridged and bisected ethyl

cations.^{2b} The calculations in the earlier study revealed a nearly constant preference for the bisected rather than bridged form in the presence of from one to five molecules of HCl. The results were attributed to several factors including the relatively low electron affinity of the bridged species due to its high LUMO energy and the fact that the total charge on hydrogens is almost the same for the bisected and bridged ions. Thus, the weaker interactions between solvent and carbons in the more delocalized ion are not compensated by increased hydrogen bonding.²⁸

The same phenomena are expected to apply to the solvation of the homocubyl isomers. The high energy of the LUMO's of **2** and **4** (Table IV) make the species relatively poor electron acceptors. Furthermore, the total charge on hydrogens for **1**, **2**, and **4** varies by only 0.05 (Table II), so significant differences in hydrogen bonding are not anticipated. In going from **1** to the more delocalized isomers the charge is primarily redistributed among the carbons. The charge on carbons in delocalized ions such as **2** and **4** is so well dispersed, however, that it essentially becomes unavailable for substantially attractive, electrostatic interactions with solvent. McMahon and Kebarle have analyzed this effect succinctly in terms of the Born equation.²²

For further assurance, the individual hydrogen bond energies for all hydrogens in **1**(C_s) and **4** have been calculated. The results are shown in Figure 6 and verify the predicted similarity of hydrogen bonding for the two ions.²⁴ From the standpoint of solvation, the major difference is that for **1** there appear to be eleven potential sites for coordination, the nine hydrogen bond sites and the two sides of the carbonium carbon, while for **4** (and **2**) the only sites are the nine hydrogen bond possibilities since no other minima were found. The coordination sites would presumably be filled by solvent molecules and the solvated leaving group. The additional solvation of **1** may be estimated from results for isopropyl since the interaction of these secondary ions with one HCl in C_s symmetry differs by less than 1 kcal/mol. When isopropyl is solvated by two HCl's, one on either side of the trigonal center, in C_s symmetry, the calculated stabilization is 23.1 kcal/mol, the second HCl providing an additional stabilization of 7.5 kcal/mol.²⁵ It is reasonable that these strong interactions with the carbonium carbon (C9) in **1** may reduce the electron demand of the ion enough to somewhat diminish its propensity for hydrogen bonding, particularly to the hydrogen at C9. However, even if this hydrogen bond is completely eliminated, the coordination of the first HCl with C9 in **1** is unmatched by any similar interaction in **4** or **2**. The more remote hydrogen bonds are anticipated to remain relatively unchanged and to stabilize the different ions comparably (Figure 6). The ethyl cation results^{2b} clearly argue that the variation in carbon solvation cannot be offset by hydrogen bonding but rather that the solvation of the first one or two solvent molecules is critically discriminating.²⁶

In summary, our model studies and electrostatic arguments²² suggest that if free ions could be formed in a medium of moderate solvating ability such as HCl, the classical ion (**1**) would be better solvated than its more delocalized isomers due to the additional coordination with the carbonium carbon. For ion pairs, the solvation would be more comparable since it would chiefly involve hydrogen bonding; however, the leaving group-cation interaction should be more stabilizing in **1**.

It must be said that the quantitative significance of the results presented here is not profound. However, the qualitative trends and implications are reasonable and important. First, it is apparent that localized carbonium ions form "tighter" ion pairs than more delocalized isomers and that additional solvation may not be compensatory. This effect implies that the relative energies of isomeric carbonium ions in the gas phase do not necessarily dictate the relative energies of corresponding

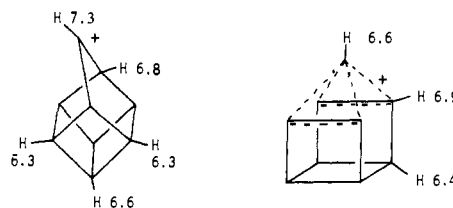

Figure 6. Calculated hydrogen bond energies for **1**(C_s) and **4** with HCl in kcal/mol.

intermediates in solution. The extent of the discrepancies depends on several variables including the difference in charge delocalization for the carbonium ions and the nature of the solvent and leaving group. A more nucleophilic counter molecule than HCl, e.g., HCOOH or CH₃COOH,²⁰ should magnify the preference for ion pair formation with a more localized carbonium ion. Thus, although the results in Table III propose that carbon scrambling in ion pairs with HCl might still be facile, the scrambling would be more difficult in complexes with a more nucleophilic counterion or solvated leaving group. This condition may well be realized during acetolyses of 9-homocubyl tosylates. Second, the results and analyses presented here can be interpreted as support for **1** representing the carbonium ion part of intimate ion pairs that occur initially during solvolyses of 9-homocubyl tosylates. Carbon scrambling is then achieved through rearrangements involving higher energy ion pairs or transition states that may be based on species such as **2** and **4**, e.g., eq 1.

The Perturbation Theory Approach

It was shown previously that a simple, second-order perturbation theory expression (eq 2-4) could be used to estimate and analyze the stabilization energies (ΔE_s) for carbonium ion-HCl complexes.^{2a}

$$\Delta E_s \propto \frac{Q_L(C^+)}{\epsilon_L(R^+) - \epsilon_H(s)} \equiv f_s \quad (2)$$

$$\Delta E_s^{\text{est}} = a f_s \quad (3)$$

$$Q_L(C^+) = \sum_i^{AO's} C_{iL}^2(C^+) \quad (4)$$

Equation 3 represents the stabilization associated with the important, frontier orbital interaction between the HOMO of the electron donating counter molecule (HCl) and the LUMO of the electron accepting carbonium ion. Specifically, $Q_L(C^+)$ is the electron density on the carbonium carbon in the cation's LUMO, if it were occupied by one electron. For simple carbonium ions, this quantity is dominated by the contribution from the vacant 2p orbital. $\epsilon_L(R^+)$ and $\epsilon_H(s)$ are the orbital energies for the LUMO of the cation and HOMO of the counter molecule. f_s is the "specific solvation factor" and is related to ΔE_s by a proportionality constant, a , that was determined empirically.^{2a}

Charge delocalization in a carbonium ion decreases ΔE_s as given in eq 2 by two means. First, $Q_L(C^+)$ at any one carbon will be small if the charge is distributed over several centers. Second, hyperconjugation leads to high LUMO energies, $\epsilon_L(R^+)$, by mixing the LUMO with lower energy, filled σ orbitals. Homoaromatic and pyramidal carbocations, e.g., **2** and **4**, also have high LUMO energies since their LUMO's have some σ^* character.^{2,23}

Using the data for the carbonium ions compiled in Table IV and the MINDO/3 value for $\epsilon_H(\text{HCl})$, -12.11 eV, ΔE_s 's can be estimated from eq 3. The results are in the sixth column of the table. For all the cations in Table IV, the carbonium carbon was taken to be the most positively charged carbon (Table II). The estimated ΔE_s for **1**(C_s) is low for a secondary carbonium ion, e.g., isopropyl and cyclopentyl both have ΔE_s^{est} 's of ca. 16

kcal/mol. The lower value for $1(C_s)$ can be attributed to significant hyperconjugation with the C1C6, C6C7, and C7C8 bonds in the isolated ion. This is revealed in the relatively high ϵ_L for $1(C_s)$ as compared to isopropyl (-7.15 eV) and cyclopentyl (-6.88 eV) and by the lengthening of the hyperconjugating bonds in $1(C_s)$ as compared to $1(C_{2v})$, viz., Figures 1 and 2. The hyperconjugation may be responsible for the moderate rate enhancement observed during acetolysis of 9-homocubyl tosylate.³ The interactions should be stronger than in 7-norbornyl cation, for example, since the hyperconjugating bonds in **1** are more strained and are in cyclobutyl rings.

The low $Q_L(C^+)$'s and high ϵ_L 's for **2**, **4**, and **5** attest to the extreme delocalization in these species. The result is ΔE_s^{est} values that fall below the hydrogen bond energies (~ 7 kcal/mol), so these ions prefer coordination of HCl with hydrogen rather than carbon. Thus, this analysis also finds that the delocalized ions are not expected to bond as strongly to a counterion or molecule in an ion pair as the more localized species, **1**. In addition, the same factors, delocalization and high LUMO energy, should lead to small substituent effects for solvolyses that generate the delocalized ions. This prediction has been verified for **5**.⁷

Acknowledgment. The author is grateful for informative discussions with Professors H. C. Brown, P. v. R. Schleyer, and R. A. Sneen. Acknowledgment is also made to the donors of the Petroleum Research Fund, administered by the American Chemical Society, for support of this work.

Supplementary Material Available: Listing of the calculated coordinates of all atoms for **1**, **2**, **4**, and 1-CIH (2 pages). Ordering information is given on any current masthead page.

References and Notes

- (1) Chemical Consequences of Orbital Interactions. 8. Part 7: ref 2b.
- (2) (a) W. L. Jorgensen, *J. Am. Chem. Soc.*, **99**, 280 (1977); (b) W. L. Jorgensen and J. E. Munroe, *Tetrahedron Lett.*, 581 (1977).
- (3) (a) P. v. R. Schleyer, J. J. Harper, G. L. Dunn, V. J. DiPasquo, and J. R. E. Hoover, *J. Am. Chem. Soc.*, **89**, 698 (1967); (b) R. E. Leone and P. v. R. Schleyer, *Angew. Chem., Int. Ed. Engl.*, **9**, 860 (1970).
- (4) J. C. Barborak and R. Pettit, *J. Am. Chem. Soc.*, **89**, 3080 (1967).
- (5) Reference 3b, footnote 39.
- (6) For a recent review, see: D. J. Raber, J. M. Harris, and P. v. R. Schleyer, "Ions and Ion Pairs in Organic Reactions", Vol. II, M. Szwarc, Ed., Wiley-Interscience, New York, N.Y., 1974.
- (7) R. M. Coates and E. R. Fretz, *J. Am. Chem. Soc.*, **97**, 2538 (1975); (b) W. L. Jorgensen, *Tetrahedron Lett.*, 3033 (1976); (c) H. C. Brown and M. Ravindranathan, *J. Am. Chem. Soc.*, **99**, 299 (1977); (d) R. M. Coates and E. R. Fretz, *ibid.*, **99**, 297 (1977).
- (8) (a) W. L. Dilling, C. E. Reinke, and R. A. Plepys, *J. Org. Chem.*, **34**, 2605 (1969); **37**, 3753 (1972); W. L. Dilling, R. A. Plepys, and R. D. Kroening, *J. Am. Chem. Soc.*, **91**, 3404 (1969); **92**, 3522 (1970); **94**, 8133 (1972).
- (9) W. G. Dauben and D. L. Whalen, *J. Am. Chem. Soc.*, **88**, 4739 (1966); **93**, 7244 (1971).
- (10) G. A. Olah, G. K. S. Prakash, and G. Liang, *J. Org. Chem.*, **41**, 2820 (1976).
- (11) R. C. Bingham, M. J. S. Dewar, and D. H. Lo, *J. Am. Chem. Soc.*, **97**, 1285 (1975), and accompanying papers.
- (12) W. L. Jorgensen, *Tetrahedron Lett.*, 3029 (1976).
- (13) W. G. Dauben, C. H. Schallhorn, and D. L. Whalen, *J. Am. Chem. Soc.*, **93**, 1446 (1971); L. A. Paquette and R. S. Beckley, *ibid.*, **97**, 1084 (1975); L. A. Paquette, J. S. Ward, R. A. Boggs, and W. B. Farnham, *ibid.*, **97**, 1101 (1975), and accompanying papers.
- (14) M. Brookhart, R. K. Lustgarten, and S. Winsteln, *J. Am. Chem. Soc.*, **89**, 6352 (1967).
- (15) W. L. Jorgensen, *J. Am. Chem. Soc.*, **97**, 3082 (1975).
- (16) For a review see: H. Hogeveen and P. W. Kwant, *Acc. Chem. Res.*, **8**, 413 (1975).
- (17) In this context, we would like to recommend a naming convention for the pyramidal carbocations. The system proposed by Cotton¹⁸ for organometallic complexes may be used. Thus, positions of attachment of the bridging group to the diene are given, followed by the term tetrahapto, the name of the diene, and the name of the bridging group. Then, **4** is 3,4,7,8-tetrahapto[4.2.0.0^{2,6}]octadienemethynyl cation and pyramidal $(CH)_6^+$ is tetrahapto[4.2.0.0^{2,6}]octadienemethynyl cation. The nomenclature may also be extended to pyramidal cations, in which π systems other than dienes are bridged. For example, Hogeveen's dication¹⁶ is pentahapto-cyclopentadienylmethynyl dication.
- (18) F. A. Cotton, *J. Am. Chem. Soc.*, **90**, 6230 (1968).
- (19) (a) R. A. Sneen, G. R. Felt, and W. C. Dickason, *J. Am. Chem. Soc.*, **95**, 638 (1973); (b) D. Darwish, S. H. Hul, and R. Tomlinson, *ibid.*, **90**, 5631 (1968).
- (20) The stabilization energies of methyl cation by HCl and HCOOH are 53^{2a} and 87 kcal/mol, respectively, according to MINDO/3. The experimental value for the former quantity is 51 kcal/mol.²¹
- (21) D. Holtz, J. L. Beauchamp, and S. D. Woodgate, *J. Am. Chem. Soc.*, **92**, 7484 (1970).
- (22) T. B. McMahon and P. Kebarle, *J. Am. Chem. Soc.*, **98**, 3399 (1976).
- (23) The LUMO of **4** resembles the π_4^* orbital of the diene.
- (24) As noted in ref 2a, the calculated hydrogen bond energies with HCl are expected to be uniformly too large by ca. 4–5 kcal/mol.
- (25) The $i\text{-Pr}(\text{HCl})_2^+$ complex is found to be unsymmetrical, though each HCl is coordinated with both the carbonium carbon and its hydrogen.
- (26) The recent results of Davidson and Kebarle²⁷ are notable in this regard, although they apply to substantially different ions. In an elegant ICR experiment they found the solvation energy difference for isoelectronic alkali cations and halide anions in acetonitrile is largely established after the addition of only four or five solvent molecules to the free ions. Contributions from outer solvent spheres, a topic along with entropy that we have not discussed here, are apparently similar.
- (27) W. R. Davidson and P. Kebarle, *J. Am. Chem. Soc.*, **98**, 6125 (1976).
- (28) Using a simple electrostatic model, similar qualitative conclusions have been reached concerning the solvation of ethyl cations: D. T. Clark, *23rd IUPAC Proc.*, **1**, 31 (1971); D. T. Clark and D. M. J. Lilley, *Tetrahedron*, **29**, 845 (1953).

A New, Simple ab Initio Pseudopotential for Use in Floating Spherical Gaussian Orbital Calculations. 2. Some Results for Hydrocarbons

S. Topiol,^{*1a} A. A. Frost,^{1a} J. W. Moskowitz,^{1b} and M. A. Ratner^{1c}

Contribution from the Departments of Chemistry and Chemistry and Materials Research Center, Northwestern University, Evanston, Illinois 60201, and the Department of Chemistry, New York University, New York, New York 10003. Received November 15, 1976

Abstract: A recently proposed model potential scheme is used to replace the 1s core orbitals for carbon in FSGO calculations. Comparisons with all-electron FSGO results indicate good agreement for C_2H_6 , C_2H_4 , C_2H_2 , C_3H_6 (cyclopropane), and $LiCH_3$.

The floating spherical Gaussian orbital (FSGO) model^{2b} allows one to perform simple ab initio electronic structure calculations without great expenditure of computational effort. At the same time it allows for easy visualization of the sepa-

ration between the behavior of the core and the valence orbitals. The pseudopotential approach to electronic structure calculations is based on just such a separation between the core and valence regions. This leads one to question whether the two